

The home of the turntable

# THE VINYL ENGINE®

For more turntable manuals and setup information  
please visit [www.vinylengine.com](http://www.vinylengine.com)

# Operating Instructions

STEREO TURNTABLE

# PL-640

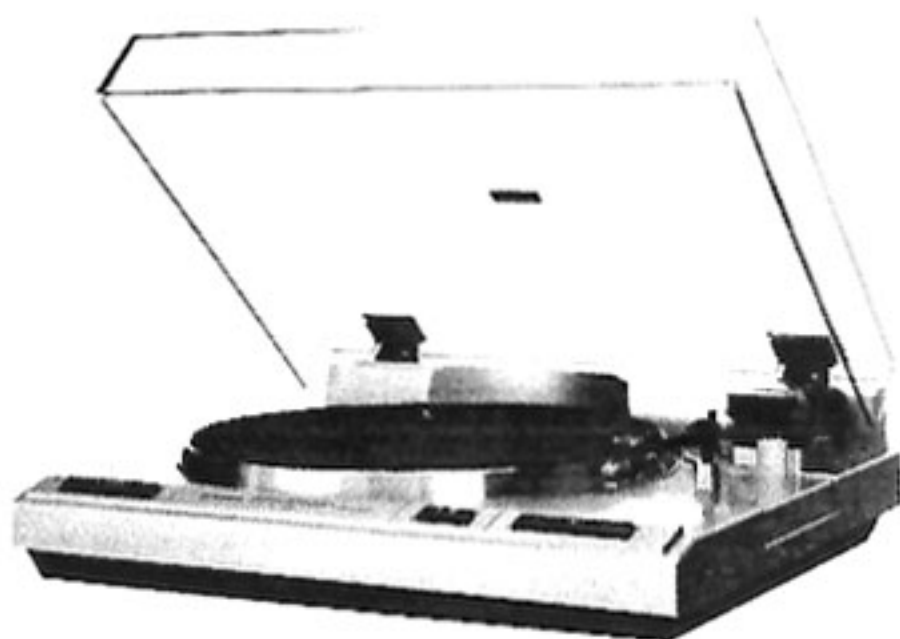

Thank you for buying this Pioneer product.

Please read through these operating instructions and then you will know how to operate your model properly. After you have finished reading the instructions, put them away in a safe place for future reference.

These operating instructions are based on the model WE, and they can be used for the WB, WP, KU, KC, R, R/G models. The differences between the models are given below.

Depending upon the model, the design of the power plug and the power outlet differs.

#### WE model:

For Europe ('WE' stamped on packing case): power line voltage is 220 – 240 volts.

#### WB model:

For U.K. ('WB' stamped on packing case): power line voltage is 220 – 240 volts.

#### WP model:

For Australia ('WP' stamped on packing case): power line voltage is 220 – 240 volts.

#### KU and KC models:

For U.S.A. and Canada ('KU' or 'KC' stamped on packing case): power line voltage is 120 volts.

#### R and R/G models:

For destinations excluding above (R or R/G stamped on packing case): A 2-point (110 – 120 V/220 – 240 V) voltage selector switch is provided.

#### IMPORTANT NOTICE [For KU and KC models]

The serial number for this equipment is located on the rear panel. Please write this serial number on your enclosed warranty card and keep in a secure area. This is for your security.

#### LINE VOLTAGE SELECTOR SWITCH

[Only R and R/G models are provided with this switch. KU, KC and other models (WE, WB, WP) are not provided with this switch.]

The line voltage selector switch is located on the top of the cabinet of this turntable. Before your turntable is shipped from the factory, the switch is set to the power requirements of the turntable's destination. Check that it is set properly before plugging the power cord into the outlet. If the voltage is not properly set or if you move to an area where the voltage requirements differ, adjust the selector switch as follows:

- Provide yourself with a medium-sized screwdriver. Insert the tip of the screwdriver into the groove of the selector switch and turn it so that the power voltage marking of your area points to the arrow.

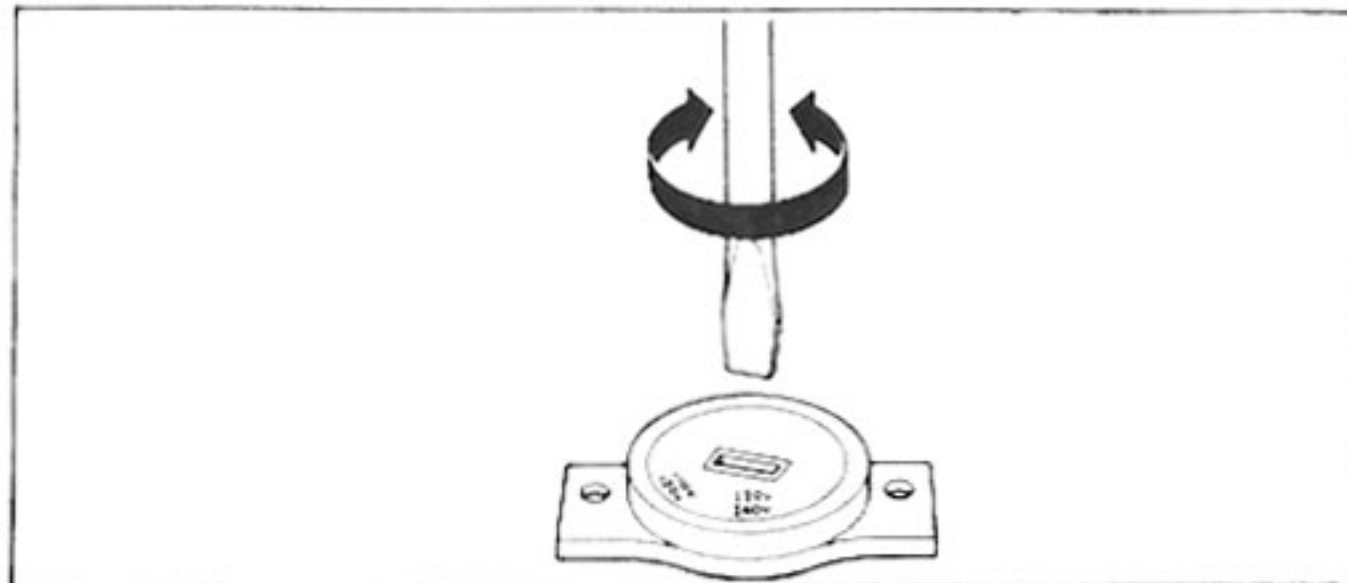

**WARNING: TO PREVENT FIRE OR SHOCK HAZARD, DO NOT EXPOSE THIS APPLIANCE TO RAIN OR MOISTURE.**

## CONTENTS

Panel Facilities .....	3	Maintenance .....	9
Operation before Use .....	4	Specifications .....	11
Record Play .....	8	Troubleshooting .....	12

# SAFETY INSTRUCTIONS (FOR KU MODEL)

**READ INSTRUCTIONS** — All the safety and operating instructions should be read before the appliance is operated.

**RETAIN INSTRUCTIONS** — The operating instructions should be retained for future reference.

**HEED WARNING** — All warnings on the appliance and in the operating instructions should be adhered to.

**FOLLOW INSTRUCTIONS** — All operating and use instructions should be followed.

**WATER AND MOISTURE** — The appliance should not be used near water — for example, near a bathtub, washbowl, kitchen sink, laundry tub, in a wet basement, or near a swimming pool, etc.

**LOCATION** — The appliance should be installed in a stable location.

**WALL OR CEILING MOUNTING** — The appliance should not be mounted to a wall or ceiling.

**VENTILATION** — The appliance should be situated so that its location or position does not interfere with its proper ventilation. For example, the appliance should not be situated on a bed, sofa, rug, or similar surface that may block the ventilation openings; or, placed in a built-in installation, such as a bookcase or cabinet that may impede the flow of air through the ventilation openings.

**HEAT** — The appliance should be situated away from heat sources such as radiators, heat registers, stoves, or other appliances (including amplifiers) that produce heat.

**POWER SOURCES** — The appliance should be connected to a power supply only of the type described in the operating instructions or as marked on the appliance.

**POWER-CORD PROTECTION** — Power-supply cords should be routed so that they are not likely to be walked on or pinched by items placed upon or against them, paying particular attention to cords at plugs, convenience receptacles, and the point where they exit from the appliance.

**CLEANING** — The appliance should be cleaned only with a polishing cloth or a soft dry cloth. Never clean with furniture wax, benzene, insecticides or other volatile liquids since they may corrode the cabinet.

**POWER LINES** — An outdoor antenna should be located away from power lines.

**NONUSE PERIODS** — The power cord of the appliance should be unplugged from the outlet when left unused for a long period of time.

**OBJECT AND LIQUID ENTRY** — Care should be taken so that objects do not fall and liquids are not spilled into the enclosure through openings.

**DAMAGE REQUIRING SERVICE** — The appliance should be serviced by Pioneer authorized service center or qualified service personnel when:

- The power-supply cord or the plug has been damaged; or
- Objects have fallen, or liquid has been spilled into the appliance; or
- The appliance has been exposed to rain; or
- The appliance does not appear to operate normally or exhibits a marked change in performance; or
- The appliance has been dropped; or the enclosure damaged.

**SERVICING** — The user should not attempt to service the appliance beyond that described in the operating instructions. For all other servicing, contact the nearest Pioneer authorized service center.

**OUTDOOR ANTENNA GROUNDING** — If an outside antenna is connected to the antenna terminal, be sure the antenna system is grounded so as to provide some protection against voltage surges and built up static charges.

In the U.S.A. section 810 of the National Electrical Code, ANSI/NEPA No. 70-1981, provides information with respect to proper grounding of the mast and supporting structure, grounding of the lead-in wire to an antenna discharge unit, size of grounding conductors, location of antenna-discharge unit, connection to grounding electrodes, and requirements for the grounding electrode. See Fig. A.

## EXAMPLE OF ANTENNA GROUNDING AS PER NATIONAL ELECTRICAL CODE INSTRUCTIONS

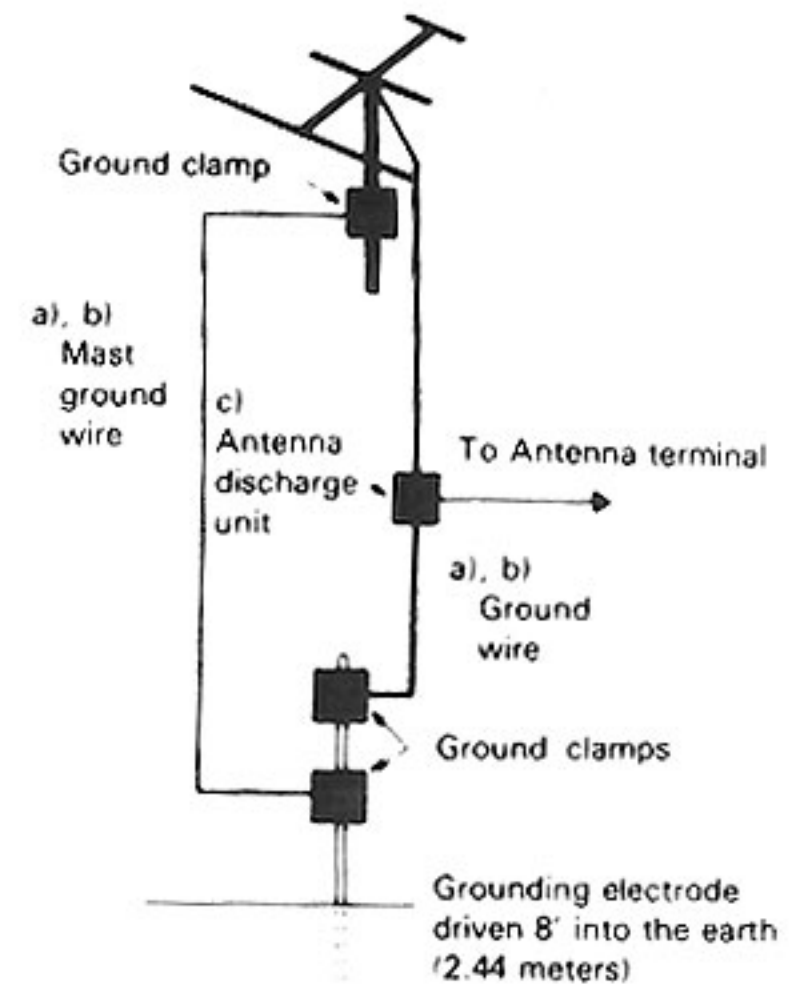

Fig. A

- a) Use No. 10 AWG (5.3 mm<sup>2</sup>) copper or No. 8 AWG (8.4 mm<sup>2</sup>) aluminum or No. 17 AWG (1.0 mm<sup>2</sup>) copper-clad steel or bronze wire, or larger as ground wires for both mast and lead-in.
- b) Secure lead-in wire from antenna to antenna discharge unit and mast ground wire to house with stand-off insulators, spaced from 4 feet (1.22 meters) to 6 feet (1.83 meters) apart.
- c) Mount antenna discharge unit as closely as possible to where lead-in enters house.

## IMPORTANT (FOR KU MODEL)



The lightning flash with arrowhead, within an equilateral triangle, is intended to alert the user of the presence of uninsulated "dangerous voltage" within the product's enclosure that may be of sufficient magnitude to constitute a risk of electric shock to persons.



**CAUTION:**  
TO PREVENT THE RISK OF ELECTRIC SHOCK, DO NOT REMOVE COVER (OR BACK). NO USER-SERVICEABLE PARTS INSIDE. REFER SERVICING TO QUALIFIED SERVICE PERSONNEL.



The exclamation point within an equilateral triangle is intended to alert the user of the presence of important operating and maintenance (servicing) instructions in the literature accompanying the appliance.

## IMPORTANT

To prevent electric shock, do not remove cover. No user serviceable parts inside, refer servicing to qualified service personnel. Always disconnect all the equipment from the mains supply when disconnecting the signal leads. The power cord should be connected last, make sure that the power switch is off.

Unplug the set from the wall socket when it is not to be used for an extended period of time.

The power switch is secondary connected and therefore does not separate the unit from main power in OFF (tonearm is on the rest) position.

### FOR USE IN UNITED KINGDOM AND AUSTRALIA

**CAUTION 240 V:** Mains supply voltage is factory adjusted at 240 V.

### FOR USE IN UNITED KINGDOM

The wires in this mains lead are coloured in accordance with the following cord:

Blue:	Neutral
Brown:	Live

As the colours of the wires in the mains lead of this apparatus may not correspond with the coloured marking identifying the terminals in your plug proceed as follows:

The wire which is coloured blue must be connected to the terminal which is marked with the letter N or coloured black.

The wire which is coloured brown must be connected to the terminal which is marked with the letter L or coloured red.

# PANEL FACILITIES

---

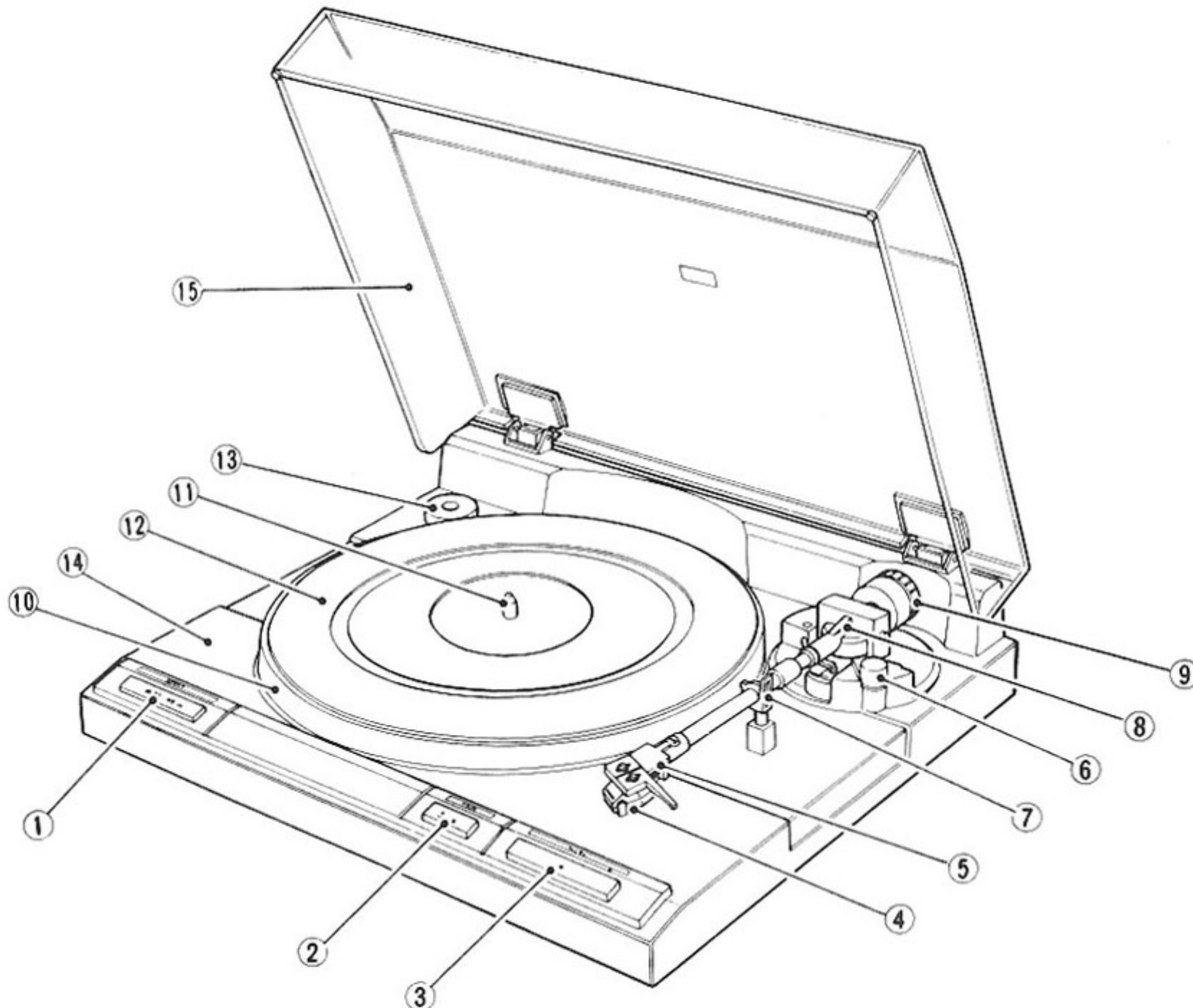

## ① SPEED SWITCH

Set this switch in accordance with the speed of the record which is to be played.

[33] (released position): For 33-1/3 rpm records.

[45] (depressed position): For 45 rpm records.

## ② ARM ELEVATION SWITCH

- Use the switch for manual operation.
- Use the switch to suspend record play temporarily.
- Use the switch when changing the tracks during actual play.

Depressed position:

The tonearm rises (the stylus moves away from the record).

Released position:

The tonearm descends (the stylus is lowered onto the record).

## ③ CUT SWITCH

Press this switch to stop play.

## ④ CARTRIDGE (PC-5MC)

## ⑤ HEADSHELL

## ⑥ ANTI-SKATE CONTROL

This is rotated when performing the anti-skating adjustment.

## ⑦ ARM REST

This serves to hold and clamp the tonearm. When moving the tonearm, release the clamp.

## ⑧ TONEARM

## ⑨ TRACKING FORCE ADJUSTMENT WEIGHT

This is used when adjusting the tracking force.

## ⑩ PLATTER

## ⑪ PLATTER SHAFT

## ⑫ RUBBER MAT

## ⑬ EP ADAPTER

This is used when playing records with a large center hole.

## ⑭ CABINET

## ⑮ DUST COVER

# OPERATIONS BEFORE USE

(Before using your turntable, carry out the instructions in **Step 1** through **Step 4**.)

## STEP 1 ASSEMBLING THE TURNTABLE

Figure of fully assembled turntable

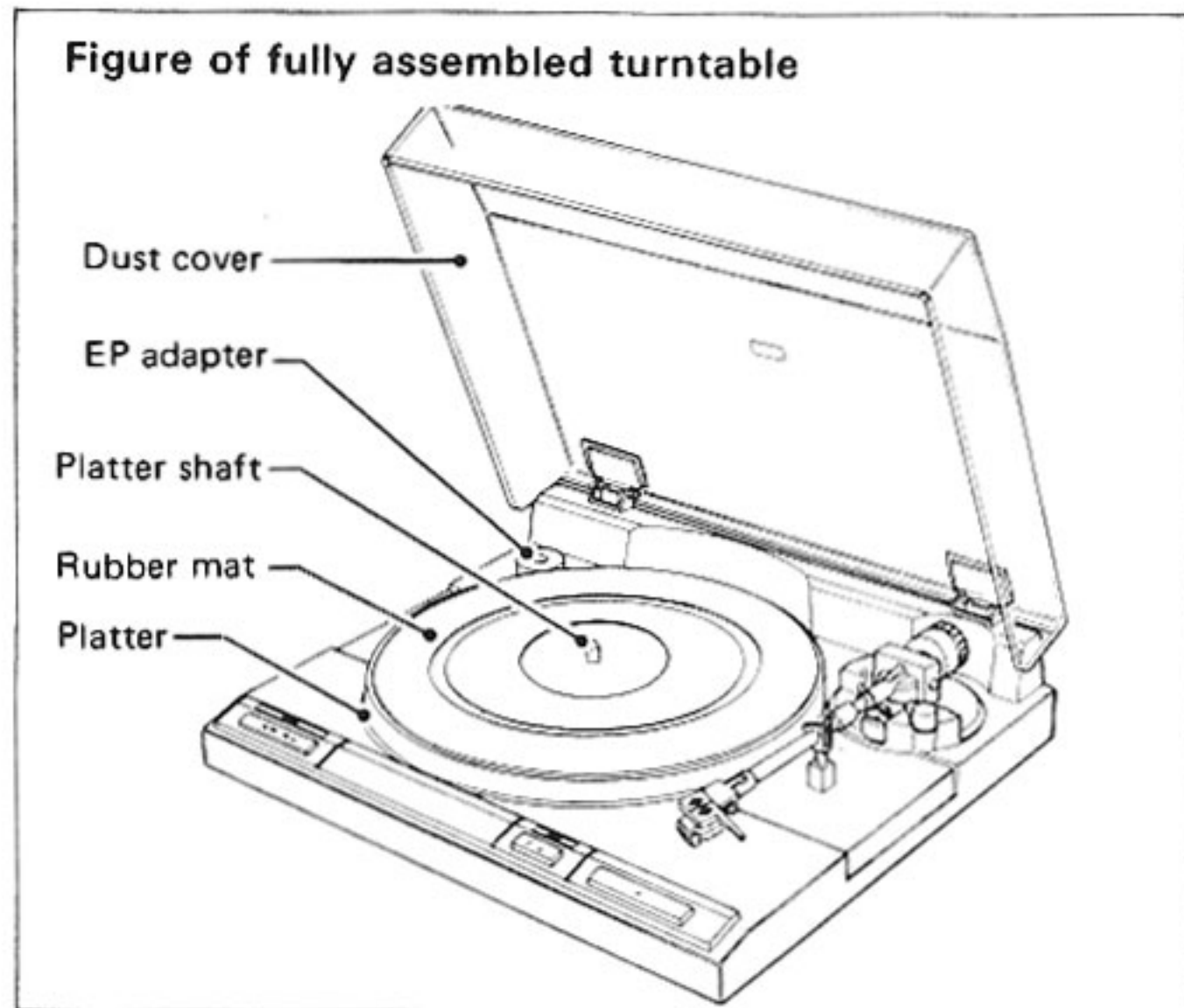

### (1) Removing the dust cover.

1. Open the dust cover as far as it will go.
2. Hold both sides of the dust cover and remove it from the cabinet by pulling it up.

**NOTE:**

Take care not to mark or scratch the dust cover which you have now removed.

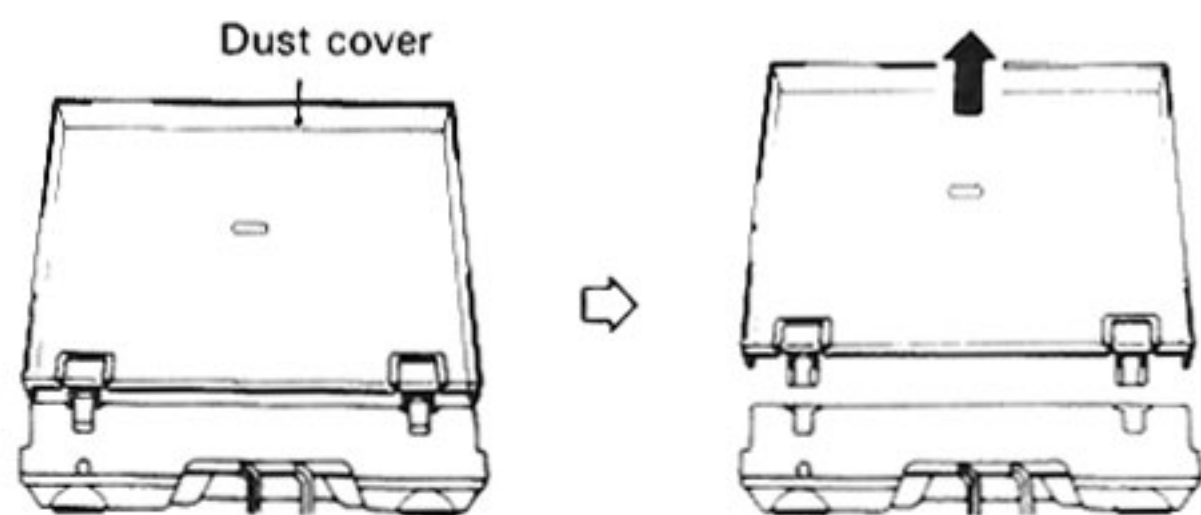

### (2) Checking the accessories and mounting parts.

Take out the rubber mat and EP adapter.



EP adapter  
(Fastened by tape to the top of the platter)

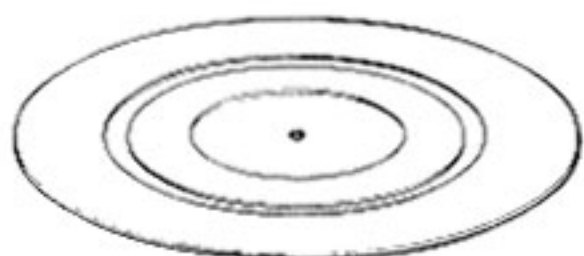

Rubber mat

### (3) Removing the transit screws.

Using a Phillips head screwdriver, rotate the transit screws (3) in the direction of the arrow in the figure and remove the platter and the platter cushions.

**NOTE:**

- The turntable will not operate unless these screws are removed.
- Keep the screws and cushions in a safe place since they are required when transporting the turntable from place to place.

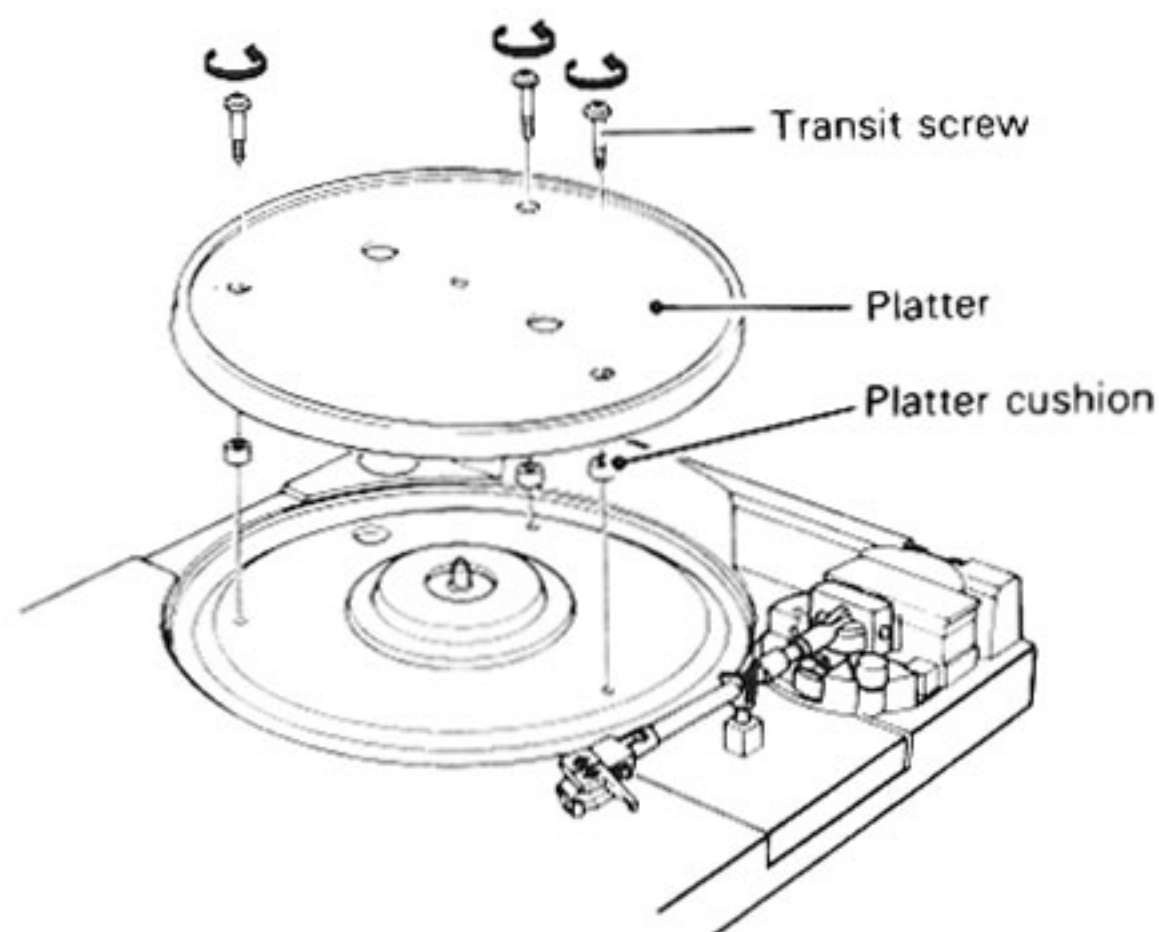

### (4) Mounting the platter and rubber mat.

1. Place the platter over the platter shaft.
2. Place the rubber mat on top of the platter.

**NOTE:**

When mounting the platter, take care not to bump it into the platter shaft, the cabinet and the tonearm.

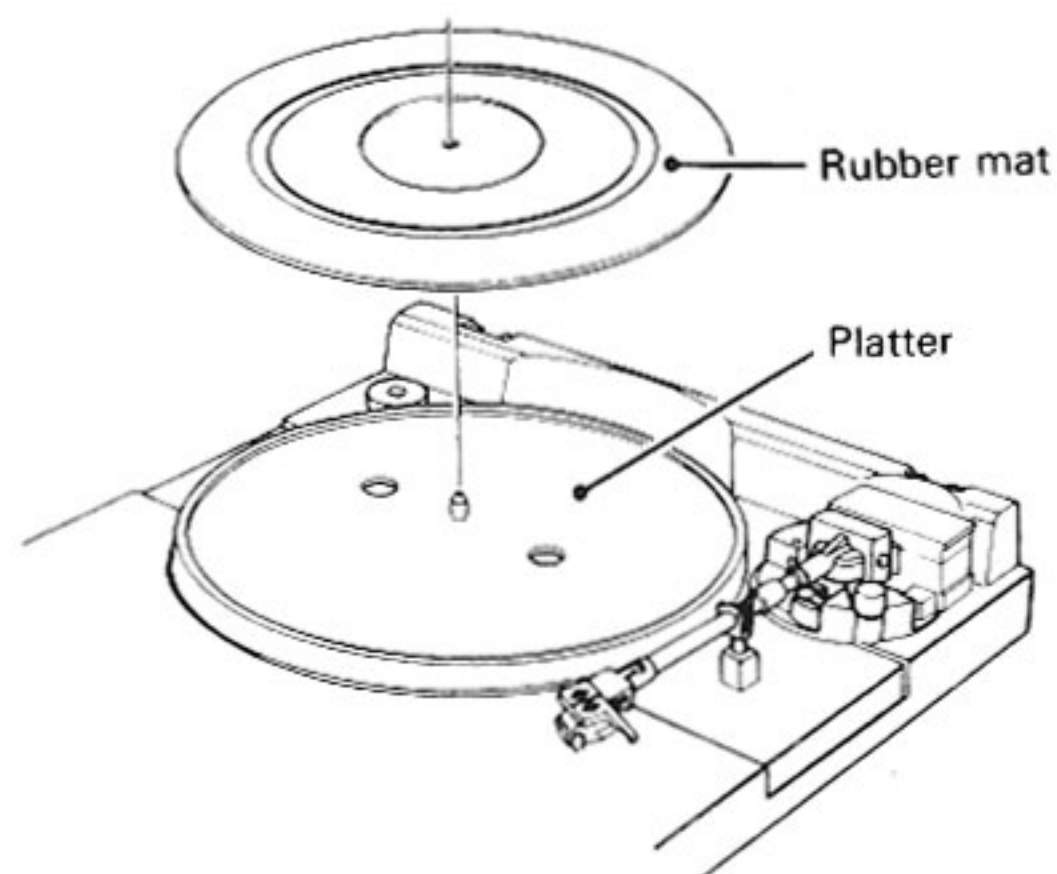

**(5) Removing the weight clamps.**

1. Raise the weight clamp A for removal.
2. Lift the weight clamp B slightly and move to the side for removal.

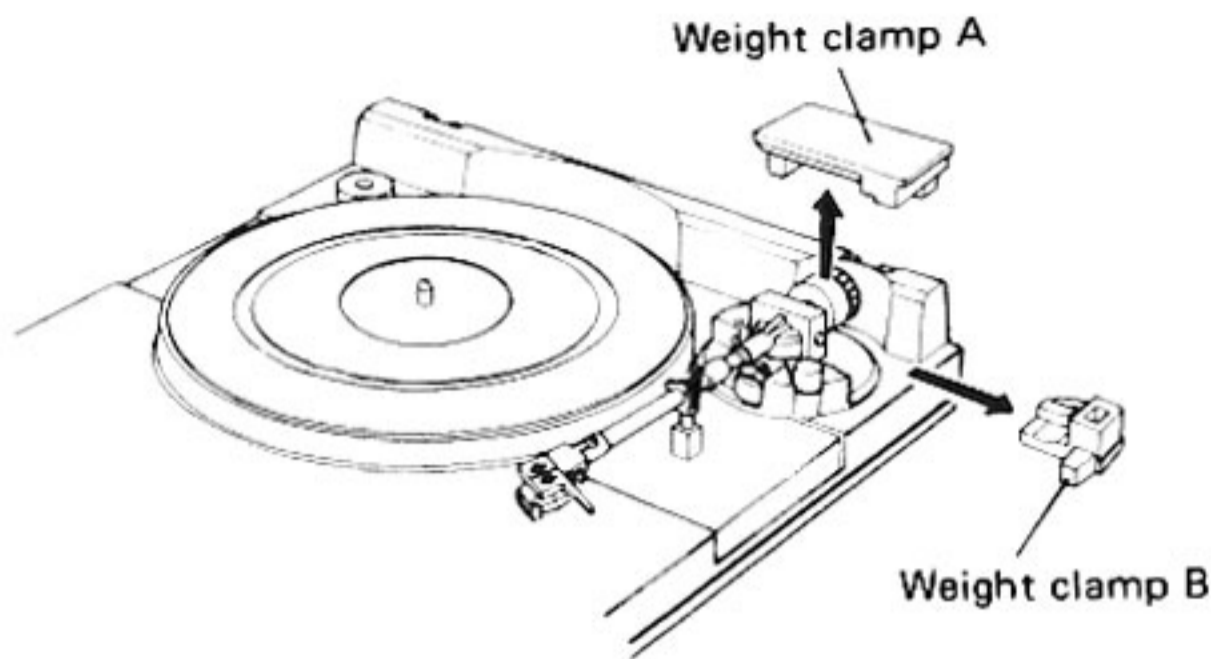

**■ Mounting the dust cover.**

1. Hold both sides of the dust cover and slide the hinges into the cabinet's hinge holders.
2. Push down until the dust cover goes no further.

*NOTE:*  
Proceed with the mounting after (STEP 2).

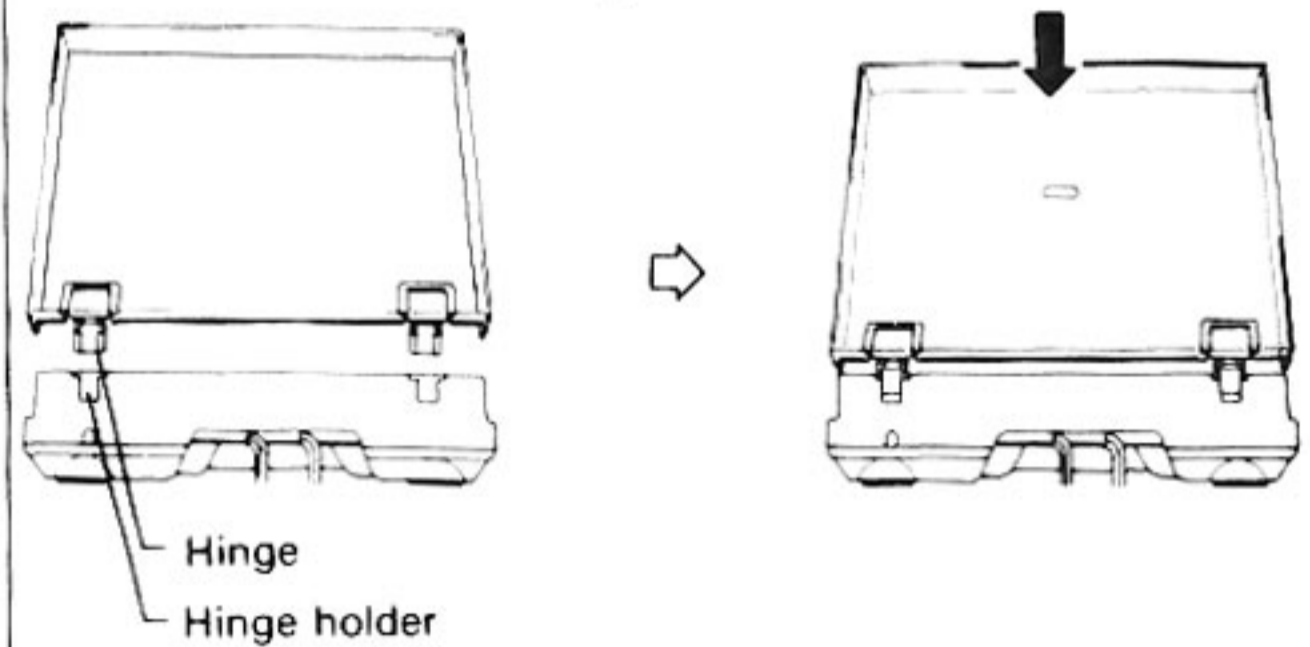

**STEP 2 ADJUSTING THE TRACKING FORCE AND ANTI-SKATING**

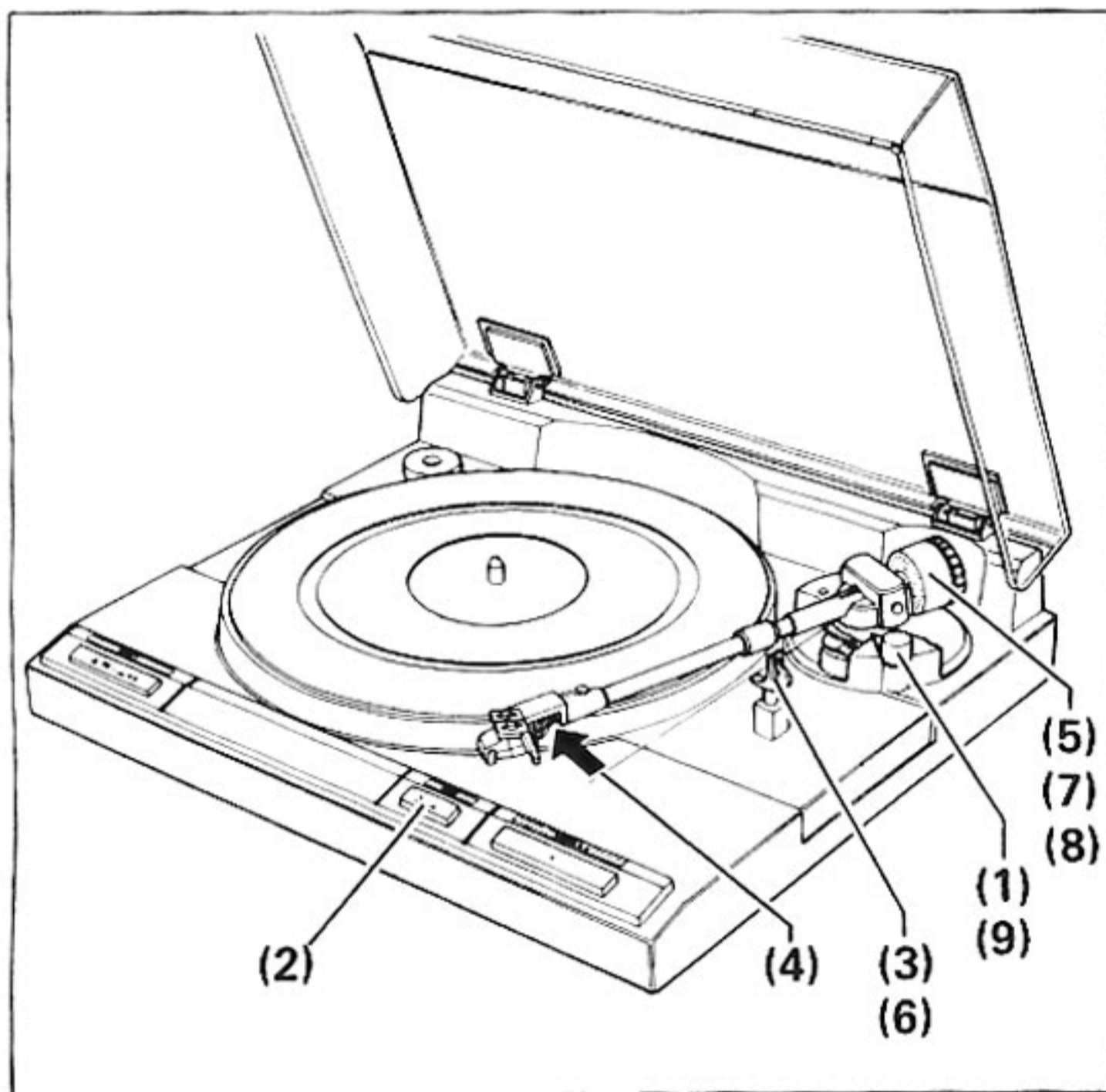

**(2) Press the ARM ELEVATION switch to the "released" position.**

Set the switch to the released position.

**(3) Releasing the arm rest.**

Move the arm rest in the direction of the arrow by hand.

*NOTE:*  
Hold the tonearm with your other hand since it may move.

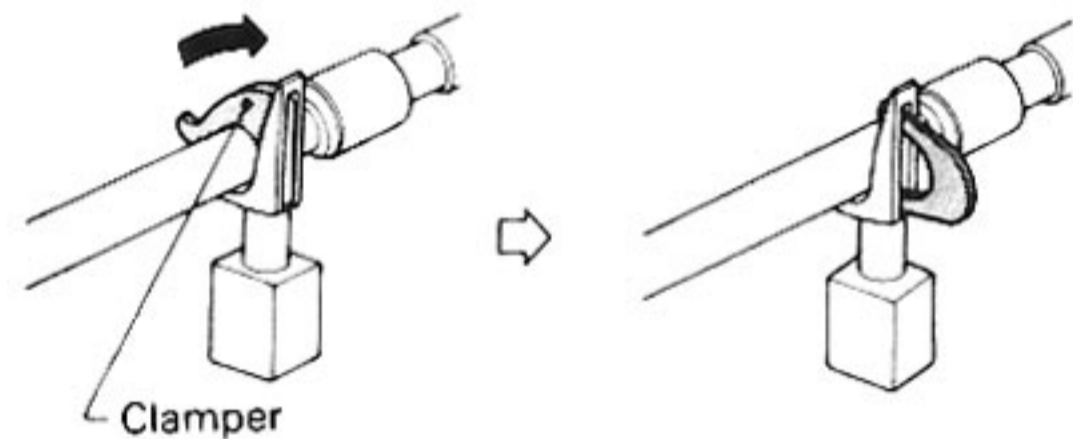

**(4) Moving the tonearm.**

Move the tonearm to between the arm rest and platter.

**(5) Attaining the horizontal balance (make the tonearm parallel).**

As shown in the figure, rotate the weight part of the tracking force adjustment weight in the direction indicated by the arrow and adjust it so that the tonearm remains parallel to the cabinet when it is released.

**(1) Setting the ANTI-SKATE control to [0].**

Rotate the control in the direction indicated by the arrow and align [0] with the index line.

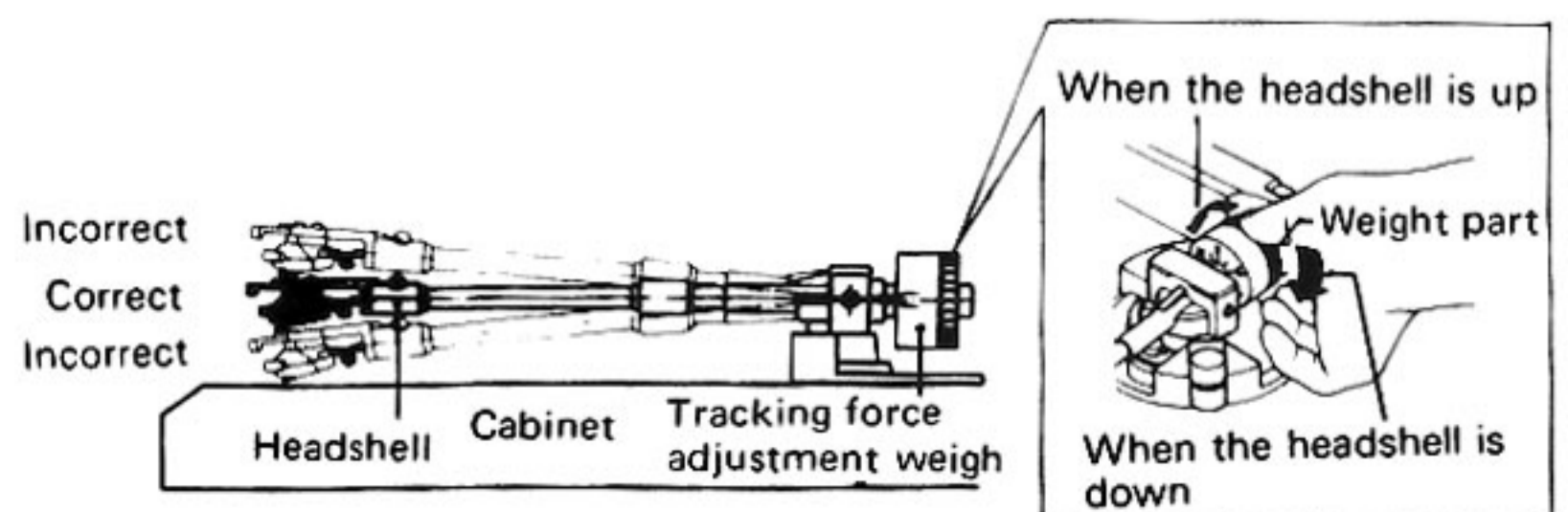
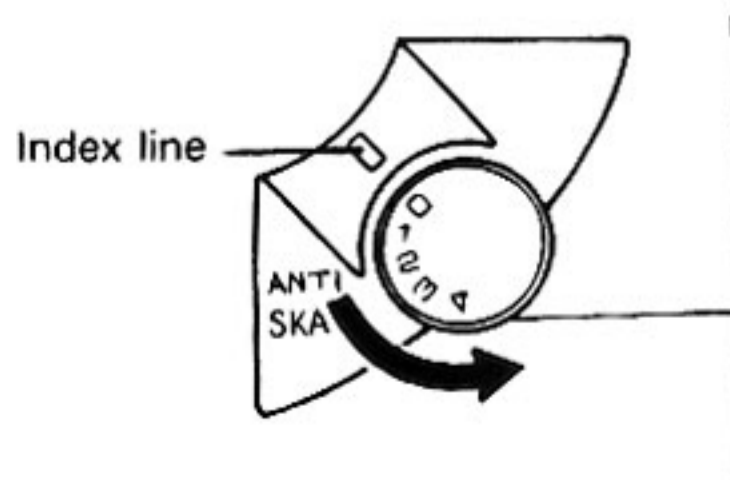

**OPERATIONS BEFORE USE**

**(6) Anchoring the tonearm to the arm rest.**

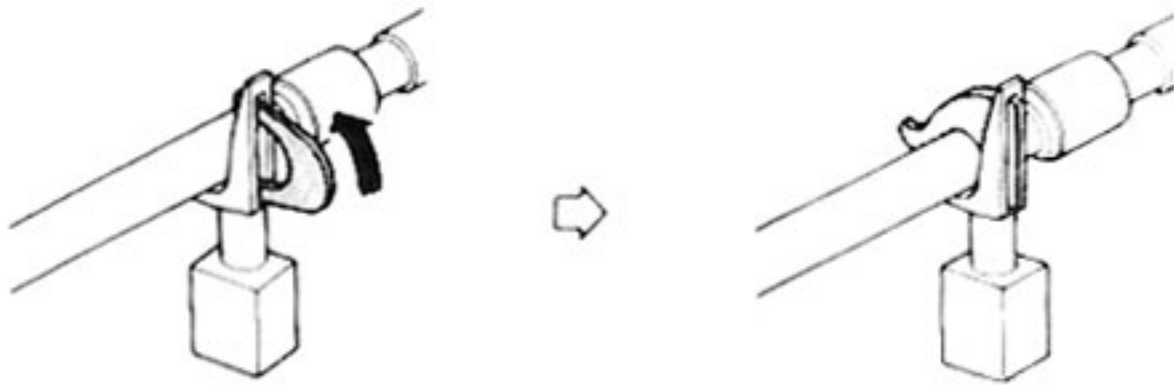

**(7) Setting the tracking force scale ring to [0].**

Rotate only the tracking force scale ring (indicated as  in figure) of the tracking force adjustment weight in either of the directions shown by the arrows and align [0] with the index line.

**NOTE:**

- Hold the weight part with your other hand to prevent it from rotating with the ring.
- Once the weight part has been rotated, attain the horizontal balance again as under section (5).

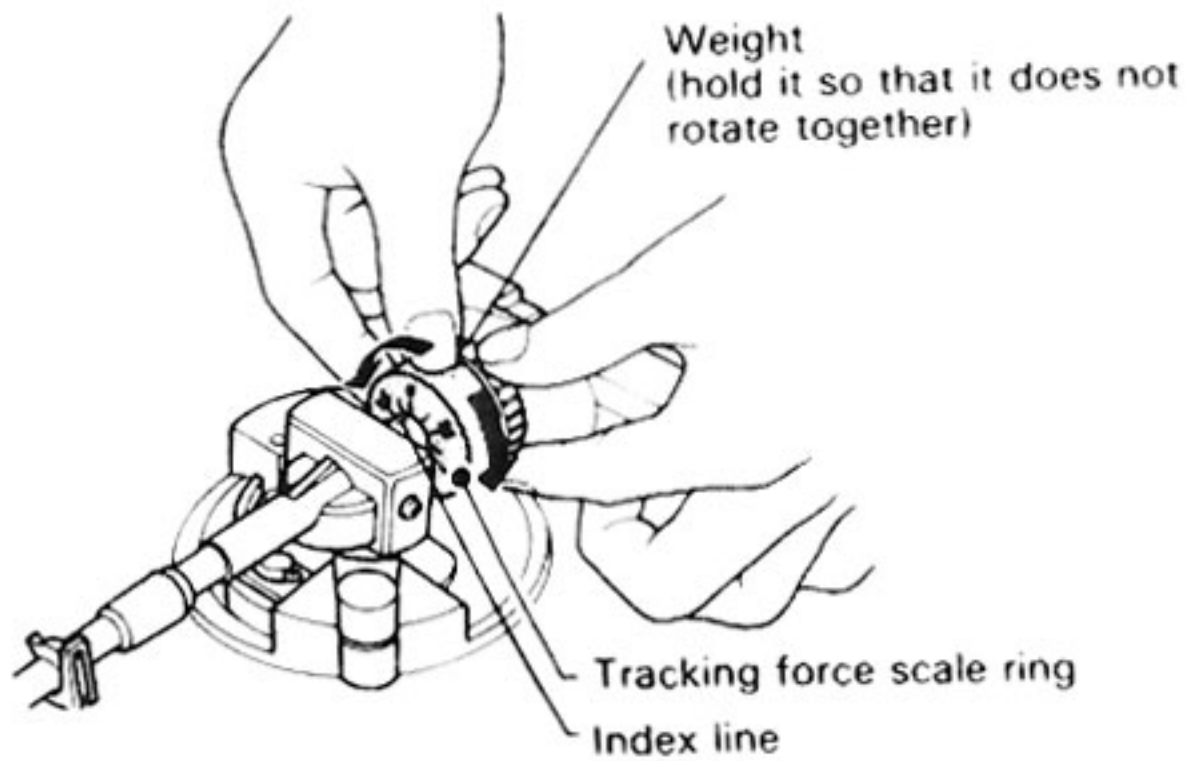

**(8) Adjusting the tracking force.**

Rotate the weight (indicated as  in figure) in the direction indicated by the arrow (the tracking force scale ring also rotates together) and align the 2 position on the scale ring with the index line.

- One scale unit on the tracking force scale ring is 0.25 g.
- A tracking force of 3 g is applied with every turn of the weight.

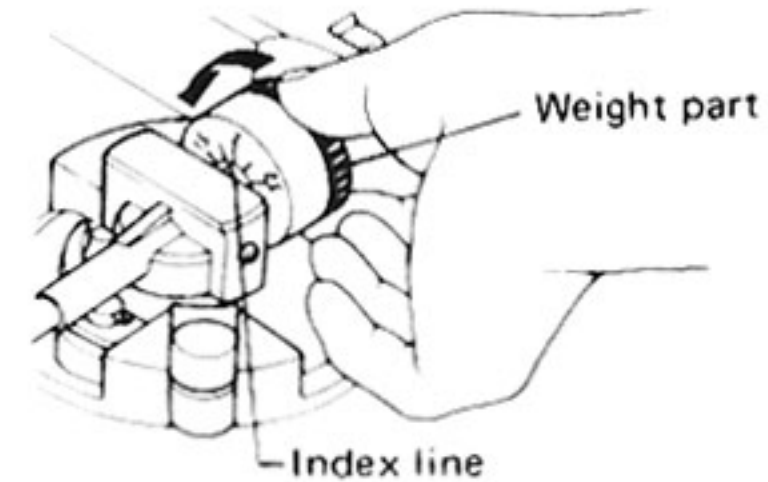

**(9) Adjusting the anti-skating.**

Rotate the anti-skating control in the direction of the arrow and align the "2" point on the control with the index line.

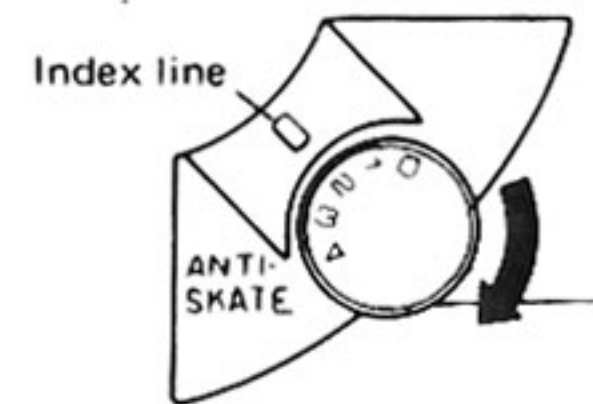

**STEP 3 CONNECTING THE TURNTABLE AND AMPLIFIER**

**Connecting the ground wire**  
Attach the metal fitting onto the amplifier ground (GND) terminal.

**Connecting the output cords**  
Insert the plugs into the amplifier's "PHONO" input terminals.  
• Connect the white plug to the left (L) channel and the red plug to the right (R) channel.  
• Insert the plugs as far as they will go.

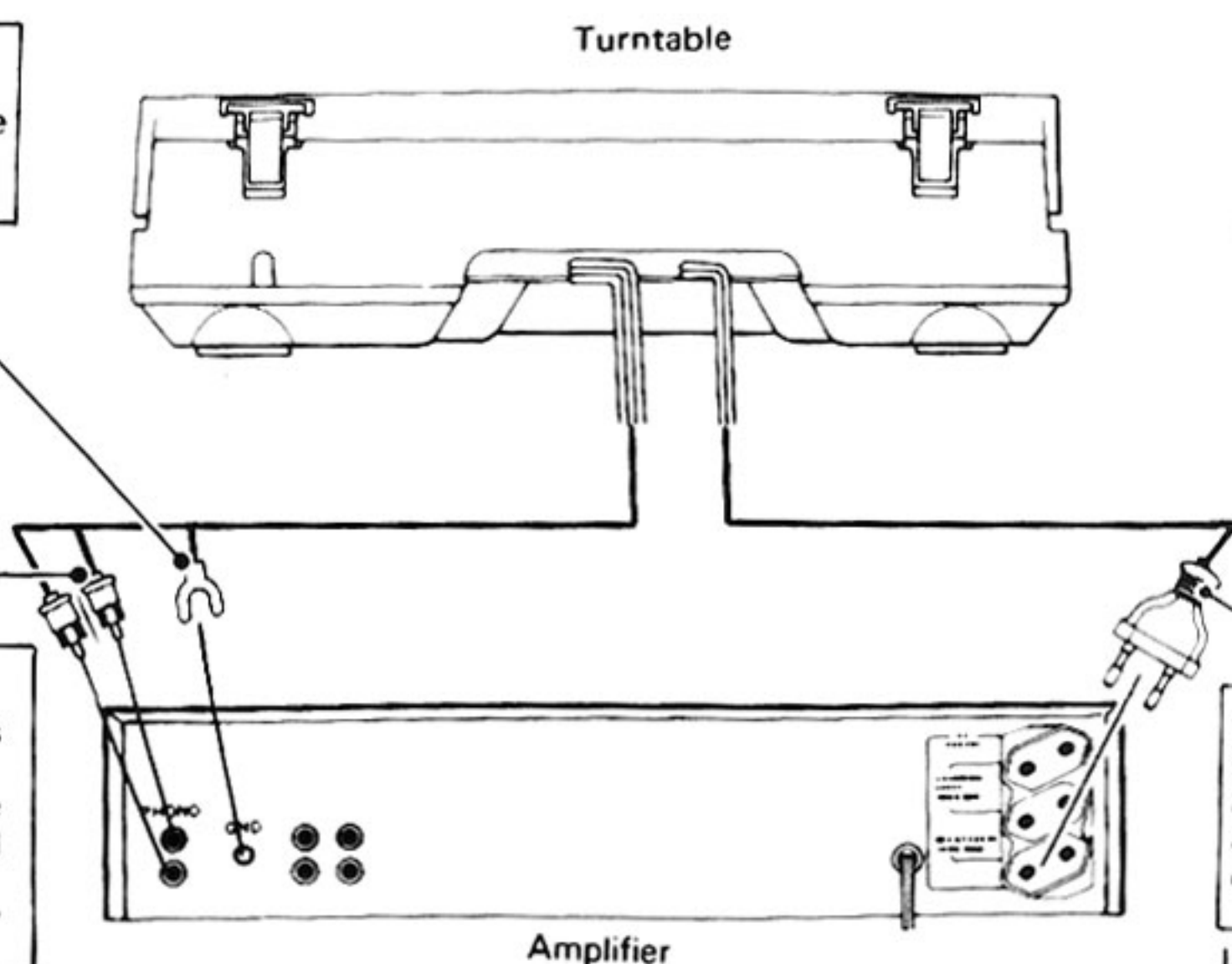

**Connecting the power cord**  
Connect the power plug to the auxiliary "AC OUTLET" on the amplifier or to a household power outlet.

Illustration not applicable to U. K. model.  
In U. K., the power plug should be connected to the "AC OUTLET" of the amplifier.

**STEP 4** INSTALLING THE TURNTABLE

Take note of the following points and install the turntable properly. Find a location which:

- Is horizontal and flat.
- Is characterized by minimal floor vibration or is not affected by any vibrations transmitted.
- Is not affected by high sound pressures or vibrations from the speaker system.  
(Do not install the turntable immediately in front of, or on top of, the speakers.)
- Allows easy operation and gives visible access to the record and stylus.
- Is near to the stereo amplifier.  
(Install the turntable within a range where the connecting cords reach the terminals on the amplifier.)
- Is not directly exposed to direct sunlight or heat from heating appliances.  
(Do not install the turntable near a heater or on a window ledge exposed to the sun.)
- Is not exposed to dust and dirt.
- Is free from damp and moist air.

After having carried out steps [1] through [4], read through the following checkpoints.

**Check the tracking force and anti-skating adjustments.**

- **The ANTI-SKATE control must be aligned with the same number as the tracking force.**

The following trouble is apparent when the number does not tally with the tracking force:

Too high:

The sound is distorted and the tonearm slides toward the outside of the record.

Too low:

The tonearm slides towards the inside of the record when the stylus descends onto the record.

- **The tracking force must be adjusted within the correct tracking force range of the cartridge.**

The following trouble is apparent when the tracking force is not properly adjusted:

Excessive tracking force:

The sound is distorted and the cartridge itself touches the record.

Insufficient tracking force:

The sound is distorted and interrupted.

- **The tracking force must be adjusted with the ANTI-SKATE control at [0].**

Unless this control is set to the [0] position, a force is generated by the anti-skating mechanism which pulls the tonearm to the right (toward the arm rest). Therefore, when attaining the horizontal balance, the tonearm is not at rest and so the operation is difficult to perform.

Even at the [0] position there may be some movement. This is due to the increased rotational sensitivity of the tonearm enabling the stylus to trace efficiently the sound grooves on the record, and it does not indicate that there is anything wrong with the turntable.

**Check the installation and connections of the turntable.**

- **Connection must be made to the amplifier's PHONO MM terminals.**

The cartridge supplied is an MC (moving coil) type although it has virtually the same high output as the output voltage of an MM (moving magnet) cartridge. The output cord should, therefore, be connected to the MM input terminals. If connection is made to the MC terminals, the sound may be indistinct or distorted and the cartridge will not be able to do full justice to its performance.

- **When using a cartridge other than that supplied:**

Consult the Operating Instructions of the cartridge and stereo amplifier and proceed.

- **Incorrect connections of installation will lead to trouble.**

If the equipment is connected improperly, no sound will be heard. If the output cord plugs are not inserted as far as they will go or if the ground wire is not connected, a humming noise will be heard through the speakers.

If the turntable is installed at an angle, the tonearm will slide on the record and the sound will be distorted. If vibrations are transmitted to the turntable, the sound may be discontinuous or it may tremble, and in some cases howl (a prolonged wailing sound from the speakers) may be heard.

- **The connecting cords should be given some slack.**

Check that none of the connecting cords are pulled taut after they have been connected. Tautness may lead to cord disconnections and howl.



# RECORD PLAY

## RECORD PLAY PROCEDURE

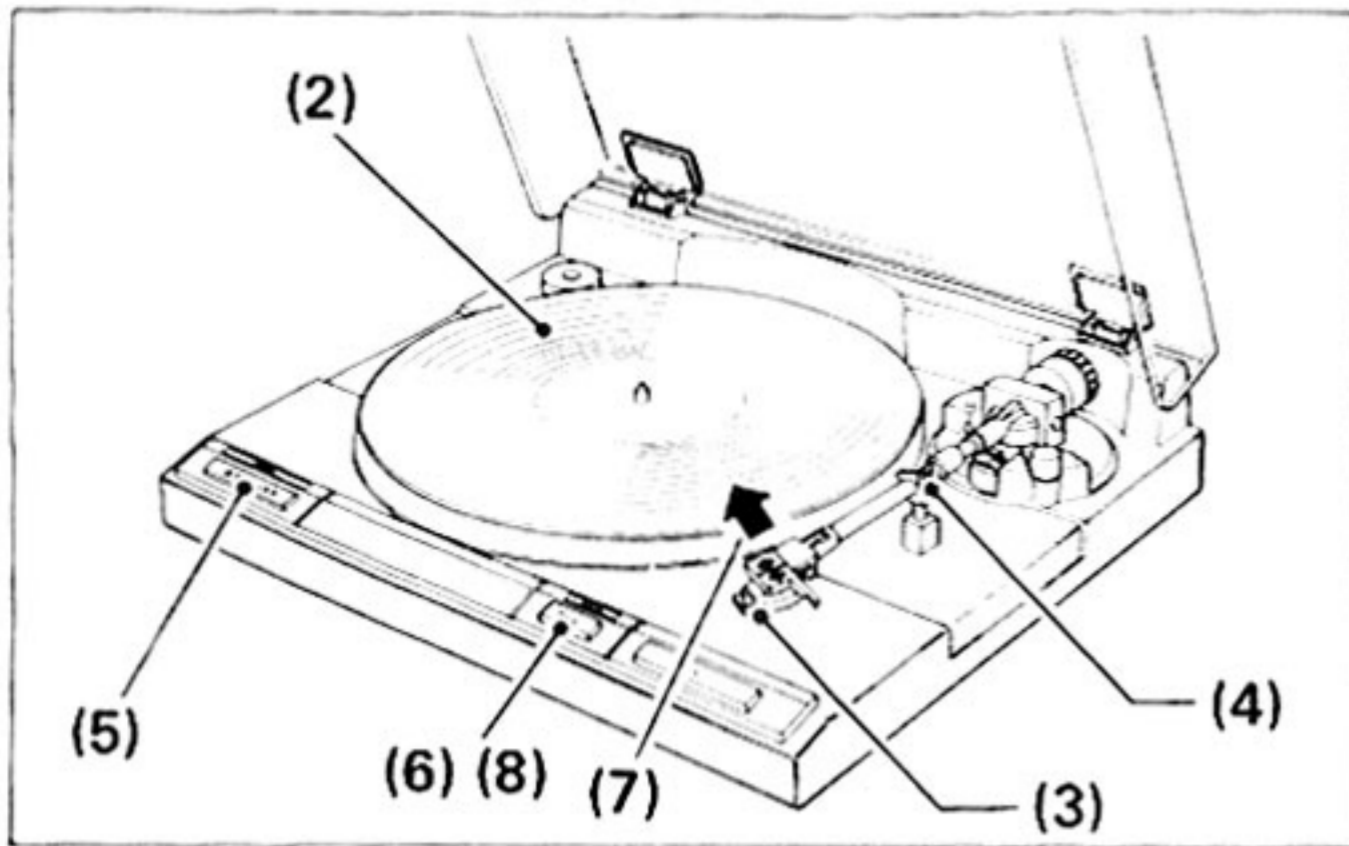

### When Using the Turntable for the First Time

The turntable may operate unstably due to the vibrations sustained during transportation. Proceed as follows to restore the turntable to its normal working operation. This procedure is observed only once; on other occasions it may be disregarded. Perform steps [1] through [7] of the record play section and then press the CUT switch. In a few seconds, the tonearm will return to the arm rest and the platter will stop rotating. (The tonearm may return to the arm rest even if the CUT switch is not pressed.)

#### (1) Set the stereo amplifier up for record play.

For details, refer to the Operating Instructions of the stereo amplifier.

#### (2) Place the record onto the platter.

#### (3) Lift up the stylus cover and expose the stylus tip.



## OPERATIONS FOR STOPPING PLAY

### When stopping play in the middle of a record

- Press the CUT switch.

Several seconds after this switch is set, the tonearm automatically returns to the arm rest and the platter stops rotating.

### When suspending play temporarily

#### (1) Press the ARM ELEVATION switch.

The stylus rises from the surface of the record and play stops (but the platter continues rotating).

#### NOTE:

When the tonearm is returned manually to the arm rest, the platter stops rotating.

After the tonearm has been returned manually to the arm rest, always remember to set the ARM ELEVATION switch to the released position.

#### (2) Press the ARM ELEVATION switch again.

The stylus descends onto the record and play begins again.

B

#### (4) Release the tonearm.

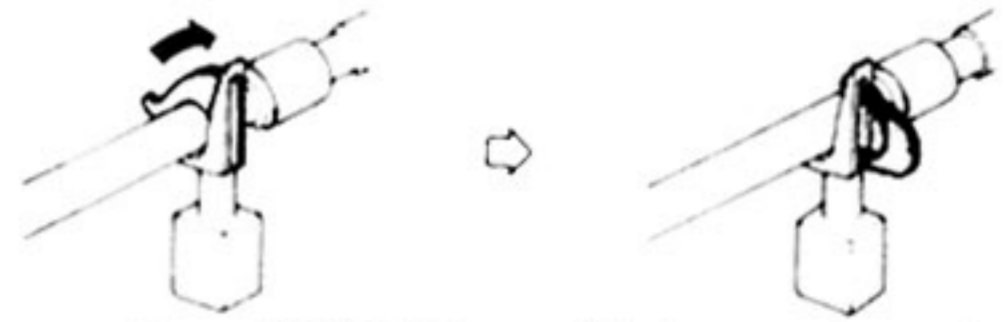

#### (5) Press the SPEED switch and set the speed:

Released position for playing 33-1/3 rpm records.

Depressed position for playing 45 rpm records.

#### (6) Press the ARM ELEVATION switch to the "depressed" position.

Set the switch to the depressed position.

#### (7) Move the tonearm by hand across to the record.

Release the headshell when the stylus has been positioned on the record at the right track.

- The platter starts to rotate.
- The stylus is still floating clear of the record and so no sound will be heard yet.

#### (8) Press the ARM ELEVATION switch and start record play.

The stylus descends onto the record and play begins.

#### (9) Adjust the volume and tone using the controls on the stereo amplifier.

(When play is completed, the tonearm returns automatically to the arm rest.)

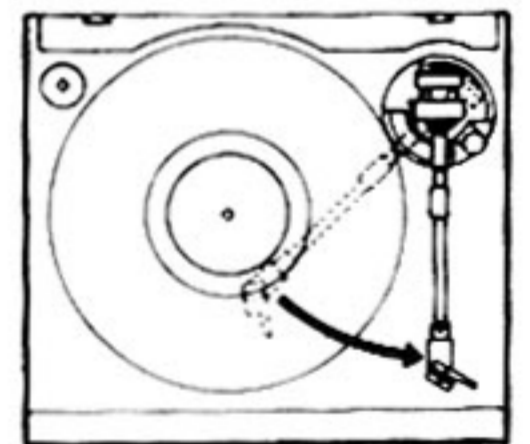

## RECORD PLAY PRECAUTIONS

- When the tonearm does not return automatically.

If a record with a non-standard size is being played, the tonearm may not return even after play or it may return before the completion of play. In cases like this, press the CUT switch and the record play is concluded automatically.

- Clean the stylus and records before and after play.

Dust or dirt on the stylus or records will result in distorted and discontinuous sound.

Remove the dust on the stylus with a soft-brush. Use a good-quality record cleaner obtainable from your dealer to remove dust and dirt on your records.

This dynamic resonance absorber (DRA) is designed to make the most of the tonearm's performance. It should not be forcibly rotated or pulled.

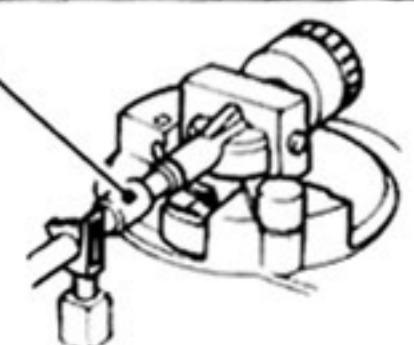

# MAINTENANCE

## REPLACING THE STYLUS

- The service life of the stylus on the cartridge supplied ranges from 800 to 1,000 hours.

(If the stylus is used for 1 or 2 hours every day, it will last for one or two years.)

Using a worn or damaged stylus can damage the record and distort the sound reproduced. Remember to replace the stylus at the earliest possible date.

- Always use the PIONEER "PN-5MC" as the replacement stylus.

The cartridge used in this turntable was developed by PIONEER and so the specially designed replacement stylus should be used. It can be purchased at your PIONEER dealer.

- Always obtain the genuine PIONEER replacement stylus.

PIONEER is not able to safeguard against deterioration in performance or possible mechanical trouble if a replacement stylus of another make is used. A genuine PIONEER replacement stylus always comes with the PIONEER mark. Check that this mark is on the stylus before purchasing it.

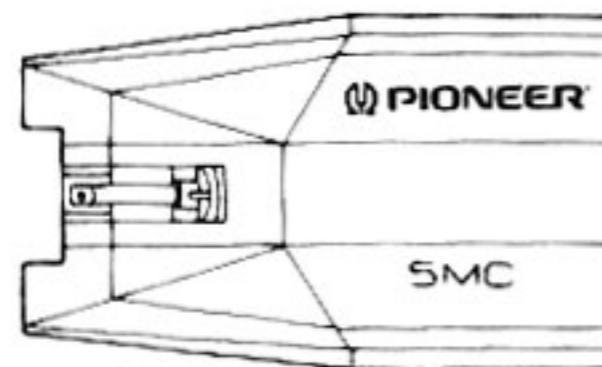

## REPLACING THE STYLUS PROCEDURE

Turn down the stereo amplifier's volume control to its lowest position for this operation.

1. Anchor the tonearm to the arm rest.



2. Remove the headshell from the tonearm.

Use a small screwdriver to rotate the anchoring screw in the direction indicated by the arrow to remove the headshell.

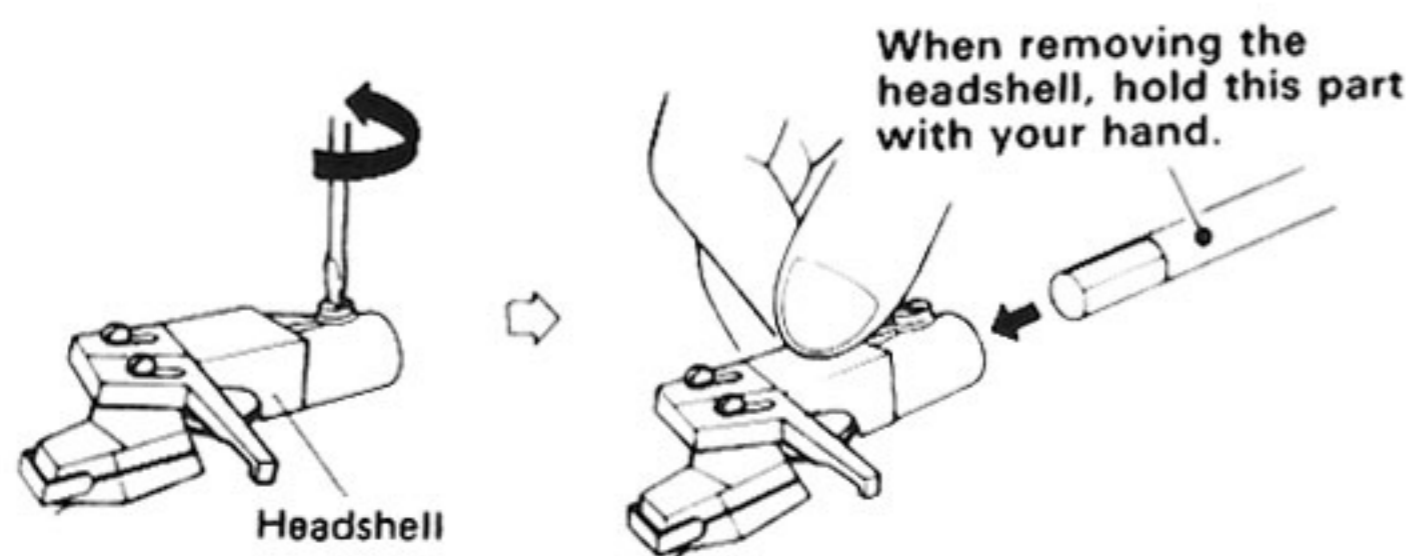

3. Remove the stylus from the cartridge. (This operation should be performed with the stylus cover removed and the stylus itself exposed.)

Hold the stylus holder and pull the stylus gently in the direction indicated by the arrow.

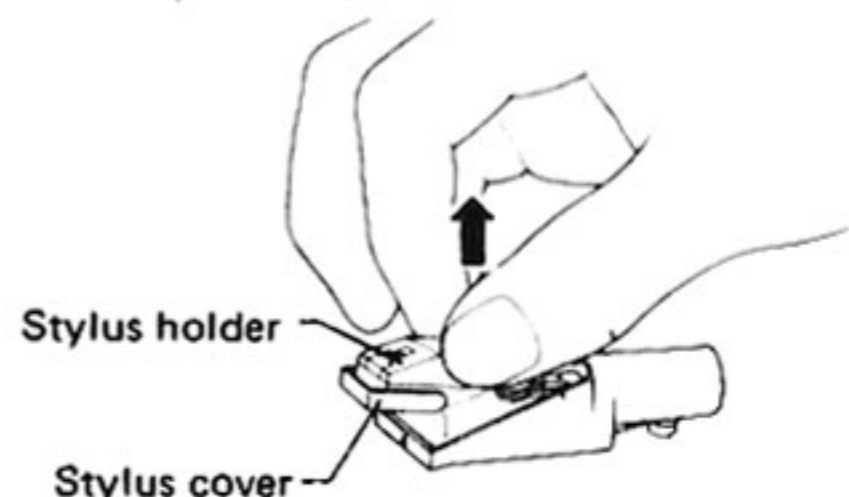

4. Attach the new stylus holder to the cartridge.



5. Mount the headshell onto the tonearm.

Follow the procedure of section 2 in reverse. Push the headshell as far as it will go and then secure it.

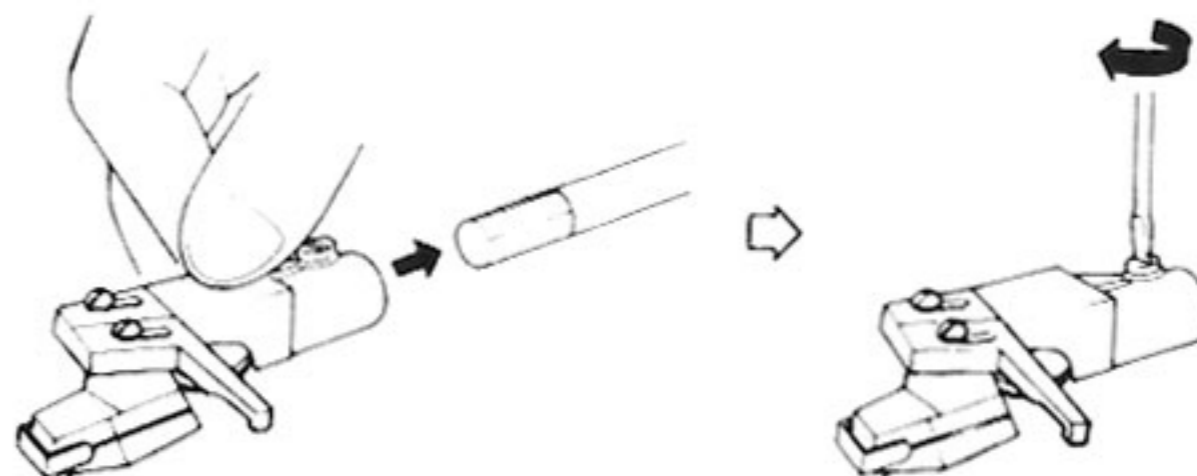

## MAINTENANCE

### MAINTAINING THE TURNTABLE

- **When the cabinet is dirty or dusty.**

Use a polishing cloth or a dry soft cloth to clean off the dirt and dust.

- **When the cabinet is stained.**

Dip a soft cloth into neutral detergent diluted with five or six times the amount of water, wring the cloth out and clean off the stains. Next, wipe off all the remaining moisture with a dry soft cloth.

- **Do not use chemicals or furniture wax.**

Never use furniture wax, cleaners, thinners or benzene for cleaning since these will mar and discolor the surface finish of the cabinet.

- **Do not spray with insecticides.**

If insecticide sprays are allowed to come into contact with the surface of the cabinet, the surface may be discolored and the finish spoiled.

### MAINTAINING THE STYLUS

- **Use a soft brush**

Move the brush toward you to clear off the dust and dirt. Do not use your finger since this will damage the stylus.

- **When the dirt cannot be removed by a brush**

Obtain some stylus cleaner from your dealer and remove. Do not allow any of the liquid to come into contact with the plastic parts as they may dissolve.

### MAINTAINING YOUR RECORDS

- **Use a good-quality record cleaner**

Cleaning records with a dry cleaner (velvet or nylon brush) may charge the records with static and generate noise. Dry cleaners and static removal sprays are more effective in getting rid of dust.

### CONDENSATION

When this turntable is brought into a warm room from previously cold surroundings or when the room temperature rises sharply, condensation may form inside and the unit may not do full justice to its performance. In cases like this, allow the unit to stand for about an hour or raise the room temperature gradually.

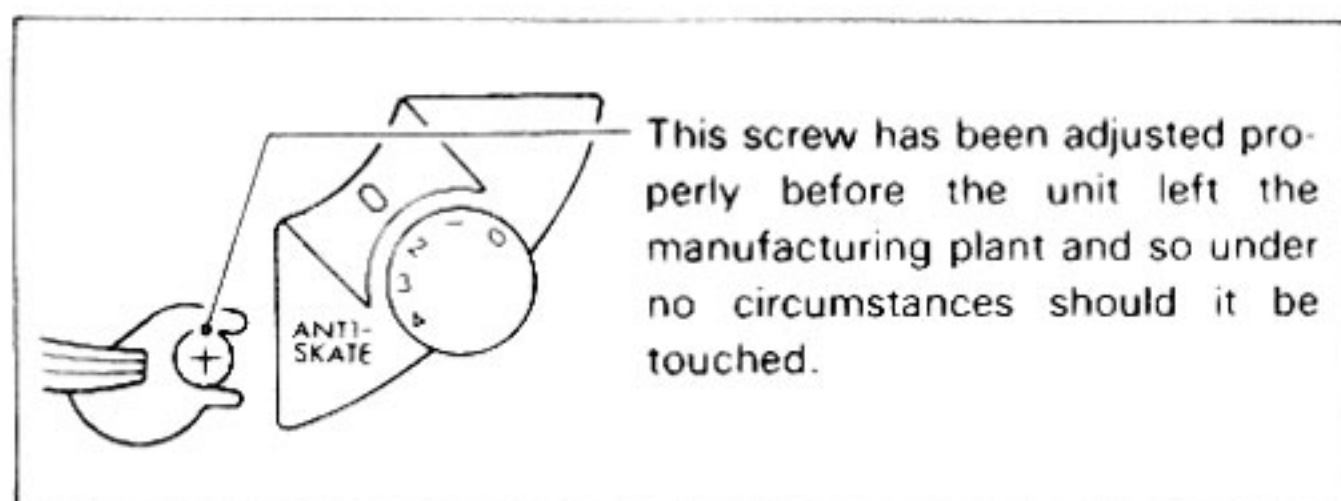

### CARTRIDGE REPLACEMENT

- Any cartridge besides that supplied having a weight of between 3 and 8 g may be used with this turntable.
- The polarities of the accessory headshell's leads are as shown below. Align them properly.

**Red: Right channel (R)**

**Green: Right channel ground (RG)**

**White: Left channel (L)**

**Blue: Left channel ground (LG)**

- The overhang of the tonearm is 15.5 mm.

When using the accessory headshell, the overhang can be adjusted when the stylus and connector dimensions are set to 56 mm.

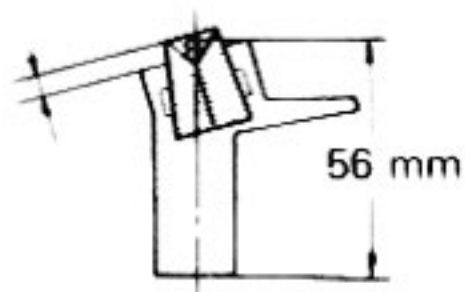

(Acceptable mounting)  
Must be mounted in  
parallel

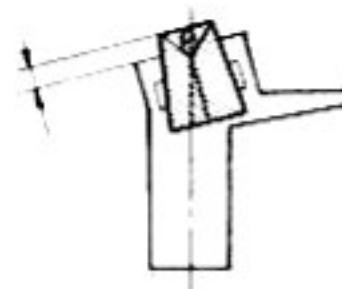

(Unacceptable mounting)  
Cartridge is bent

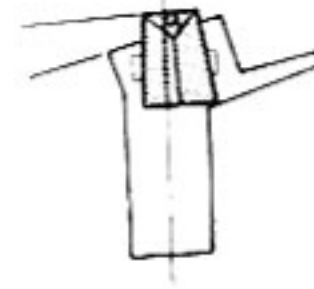

- After having replaced the cartridge, perform the tracking force and anti-skating adjustments again.

# SPECIFICATIONS

---

## Motor and Turntable

Drive System .....	Direct-drive
Motor .....	Quartz PLL Hall motor
Turntable Platter .....	304 mm diam. aluminum alloy die-cast
Speeds .....	33-1/3 and 45 rpm
Wow and Flutter .....	Less than *0.012% (WRMS) 0.025% (WRMS) ± 0.035% WTD Peak (DIN)

Values marked with an "\*" designate the wow and flutter for motor, and do not include the cartridge or tonearm load.

Signal-to-Noise-Ratio .....	More than 78 dB (DIN-B) (with Pioneer cartridge model PC-5MC)
-----------------------------	--

## Tonearm

Type .....	Static-balance type, Straight pipe arm
Effective Arm Length .....	221 mm
Overhang .....	15.5 mm
Usable Cartridge Weight .....	3 g (min.) to 8 g (max.)

## PC-5MC Specifications

Type .....	Moving coil type
Stylus .....	0.5 mil diamond (PN-5 MC)
Output Voltage .....	2.2 mV (1 kHz, 5 cm/s LAT. Peak)
Tracking Force .....	1.7 g to 2.3 g (proper 2 g)
Frequency Response .....	10 to 32,000 Hz
Recommended Load .....	50 kΩ
Weight .....	3.3 g

## Subfunctions

Auto-return, Auto cut, Quick play, Anti-skating, Arm elevation, Tracking-force direct-readout, Free stop hinges

## Miscellaneous

### Power Requirements

WE, WB, WP models .....	AC 220–240V~, 50, 60 Hz
KU, KC models .....	AC 120V~, 60 Hz
R, R/G models .....	110 – 120 V/220 – 240 V~ (switchable), 50, 60 Hz

### Power Consumption

WE, WB, WP models .....	8W
KU, KC models .....	8W
R, R/G models .....	5W

Dimensions .....	420 (W) x 118 (H) x 365 (D) mm 16-9/16 (W) x 4-5/8 (H) x 14-3/8 (D) in.
------------------	--

Weight .....	5.3 kg/11 lb 11 oz
--------------	--------------------

## Accessories

EP Adapter .....	1
Operating Instructions .....	1

### NOTE:

*Specifications and design subject to possible modification without notice, due to improvements.*